

## PHY2250 - Electronics & Circuit Theory, "Practice" Test 1

Charge on the electron:  $-1.602 \times 10^{-19} \text{ C}$

**Part I. Multiple Choice: For these questions, simply giving the answer will do, i.e. you do not need to show your work.**

- (4 points) One coulomb-per-second is equal to one:
  - watt
  - joule
  - volt
  - ampere
- (4 points) Two resistors,  $R_A$  &  $R_B$ , are placed in parallel. If  $R_A > R_B$  and a voltage is applied across this resistor combination, which resistor will dissipate more power?
  - $R_A$
  - $R_B$
  - They will dissipate the same amount of power
  - Impossible to determine; need more information to answer
- (4 points) How should one measure current and voltage in a circuit?
  - both ammeter and voltmeter in series
  - both ammeter and voltmeter in parallel
  - ammeter in parallel, voltmeter in series
  - ammeter in series, voltmeter in parallel
- (4 points) What would be the voltage drop across two  $25\Omega$  resistors in parallel if the source voltage were equal to  $9\text{V}$ ?
  - $50\text{V}$
  - $25\text{V}$
  - $12\text{V}$
  - None of the above
- (4 points) The smallest unit of an element is:
  - A compound
  - An atom
  - An electron
  - A molecule
- (4 points) The output voltage will always \_\_\_\_\_ when a load is connected across a voltage divider.
  - decrease
  - increase
  - remain the same
  - All of the above could be considered true.
- (4 points) At the Grammys, Soulja Boy had a toaster connected to a power supply, with a given voltage and current. Amy Winehouse then connected her hair drier in series with the toaster (due to a poorly-designed power strip). When she did this, the voltage across Soulja's toasta' \_\_\_\_\_, and the current through the toasta' \_\_\_\_\_.
  - increased; increased
  - increased; decreased
  - decreased; increased
  - decreased; decreased

**Part II. Definitions/Concepts:**

8. (8 points) Rob G. has a favorite resistor to use, with the color bands Red, Orange, Blue and Gold. What is the value of Rob's favorite resistor (with tolerance)?

9. (8 points) The "200 mV" setting on a multimeter means what? In other words, when would you use such a setting?

10. (8 points) Describe the two rules of Kirchoff which apply to circuit analysis. (Don't just name them; describe them)

**Part III. Problem Solving. \*SHOW ALL WORK\* to receive *nonzero* credit. When in doubt, explain what you're doing...**

11. (12 points) If a battery develops 1.6V across its terminals when unloaded (i.e. not connected to anything), but only 1.5V when it is connected to a 50-Ω load, what is the internal resistance of the battery?

12. (9 points) A particular AC signal is 3V peak to peak, with a period of 50μs.

- a. What is the amplitude?
- b. What is the RMS voltage?
- c. What is the frequency?

13. (18 points) For the following circuit, find...

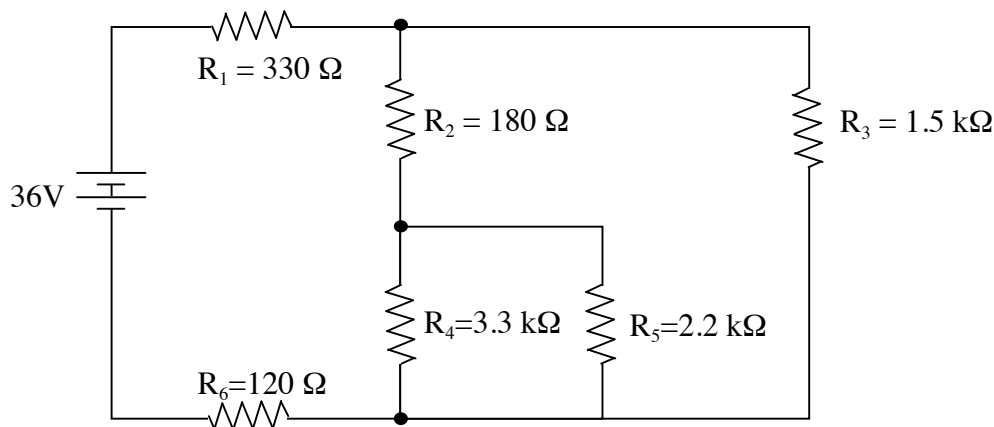

- a. the current through the 120-Ω resistor.
- b. the voltage across the 180-Ω resistor.
- c. the power dissipated by the the 1.5-kΩ resistor.

15. (9 points) If  $1.8 \times 10^{10}$  electrons flow through a resistor in 100s when 20V is applied across it, what is the resistance?